

GENERAL SPECIFICATION & DESCRIPTION

Furnish and install Streivor Air Systems Hood Model ICBD _____ as shown on Streivor's Hood Plan(s) and in accordance with the following specifications.

APPROVALS

The hood shall be UL710 Listed (Exhaust Hoods without Fire Dampers) and fitted with UL 1046 classified filters.

COMPLIANCE

The hood shall be manufactured in compliance with the prevailing National Fire Protection Agency Standard #96 and National Sanitary Foundation Standard #2.

APPLICATION

The hood shall be installed over commercial cooking appliances to remove heat and other contaminants produced during the cooking process.

DESIGN

The hood shall be an exhaust only Island Canopy design that includes full length double filter bank sized to accommodate the specified exhaust air volume. The ventilator shall be installed against a back wall Island, or in a back-to-back configuration. The hood shall have a grease drip tray beneath the lower edges of the filters, the grease drip tray shall be kept to the minimum size needed to collect grease draining from the filters. The grease drip tray shall be pitched to drain into an enclosed metal container having a capacity not exceeding 1 gallon.

CONSTRUCTION

The hood shall have 16-gauge stainless steel sides with a 4" double wall hem along the entire lower edge. Materials thinner than 18 gauge shall not be used. All seams shall be welded and/or have a listed liquid tight construction. All exposed surfaces shall be stainless steel with a #4 polish, all exposed welds shall be ground smooth to the original finish.

EXHAUST AIR

The exhaust airflow of the hood shall be determined by the Manufacturer's listing and the type, size, and position of the cooking appliances to be installed under the hood.

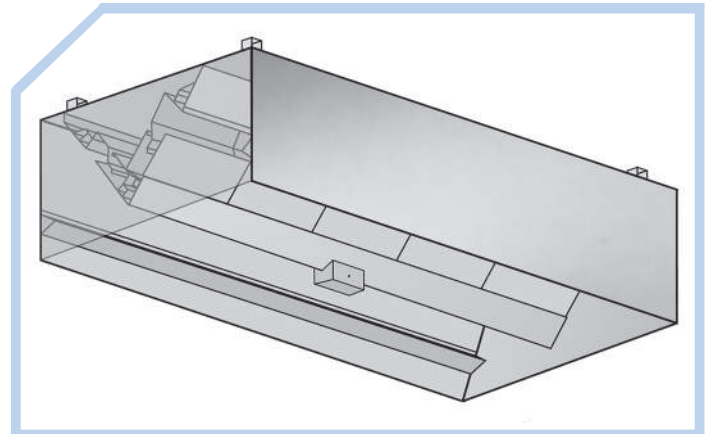

OPTIONS & ACCESSORIES

- UL1046 Classified Filters:
 - Baffle Filters
 - Baffle Filters w/ Spark Arrestor
 - High Velocity Non Loading Cartridge
 - UL710 Listed Balancing Damper (Internally-Adjustable, Opposed-Blades):
 - Manual
 - Motorized
 - LED Light Fixtures:
 - Surface Mounted
 - Recessed
 - Auto-Start Temperature Monitors
 - UL710 Listed Access Enclosure(s)
 - Side Containment Panels:
 - Light Duty
 - Heavy Duty
 - Make-Up Air Plenums
 - Hood Mounted Utility Cabinet
 - Cold Water Misting for Solid Fuel Cooking
 - Rotating Auto Wash System
 - Ultraviolet Technology
 - Ceiling Enclosure Panels
 - Wall Flashing:
 - Flat
 - Insulated
- * See hood drawings for project specific options and accessories.**

FIRE SUPPRESSION SYSTEM

UL300 compliant FSS required for Type-1 grease applications.



PLAN VIEW

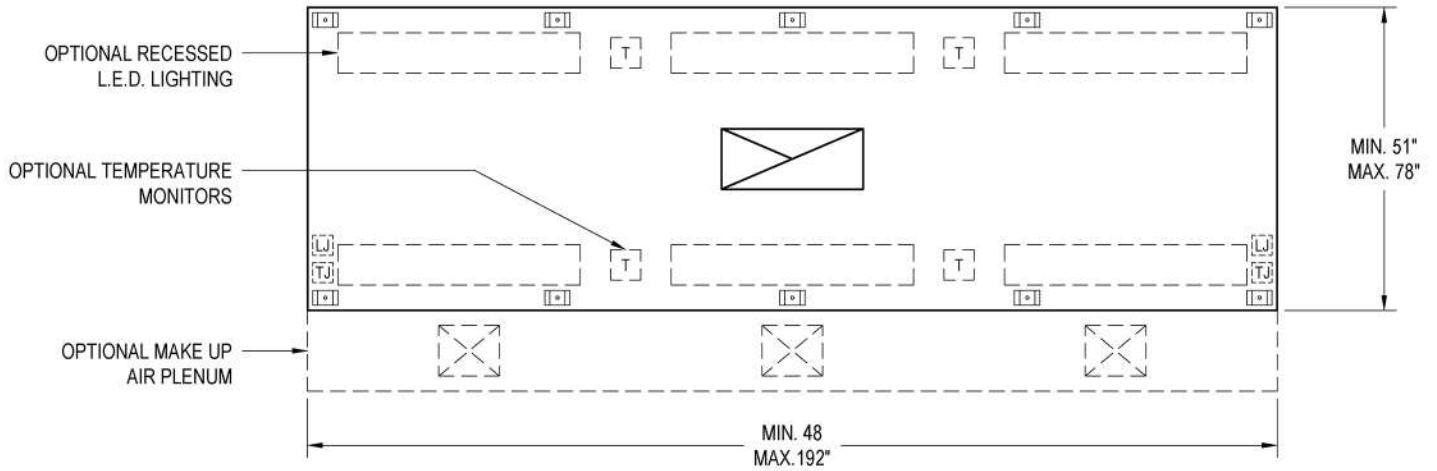

SECTION VIEW

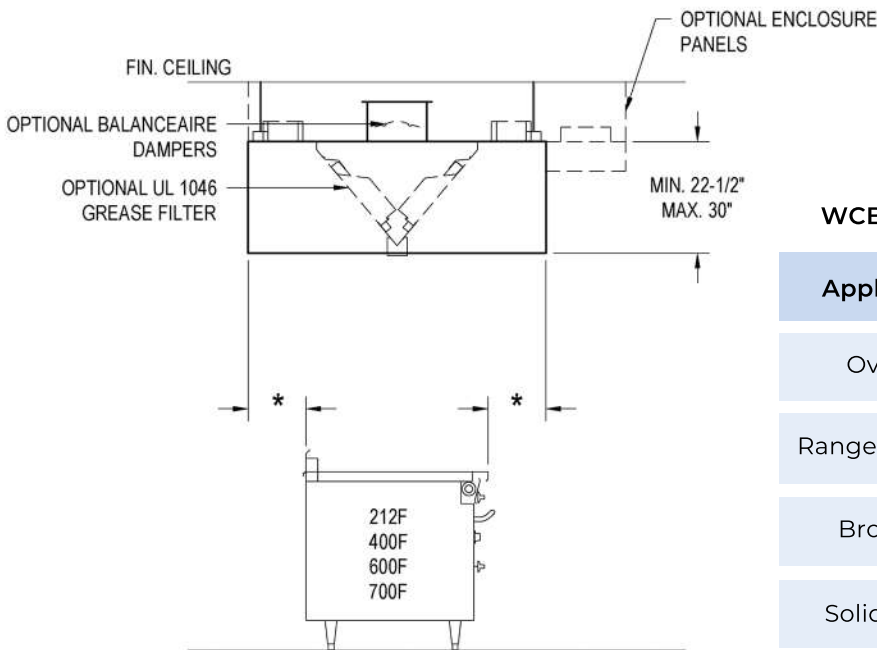

* SEE HOOD DRAWING FOR EXHAUST AND MAKE-UP AIRFLOW RATES



WCBD Hoods are Listed for Installation Over:

Appliance	Duty	Temp
Ovens	Light	212°F
Ranges/Fryers	Medium	400°F
Broilers	Heavy	600°F
Solid Fuel	Extra Heavy	700°F